

# Magnetic Imaging Techniques

Laura Heyderman

ETH Zurich & Paul Scherrer Institut, Switzerland

# Types of Magnetism

***Ferromagnetism***

***Helimagnetism***

***Antiferromagnetism***

***Ferrimagnetism***

***Spin-Canted Magnetism***

***Paramagnetism***

# Types of Magnetism

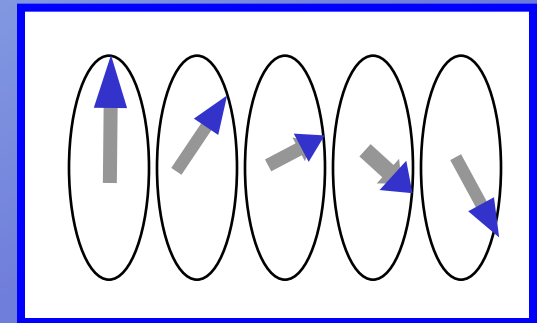
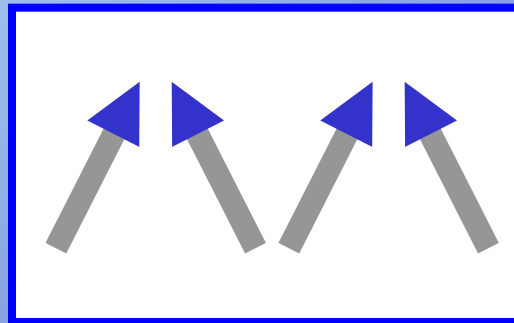
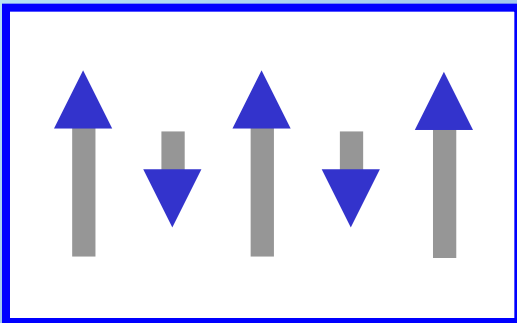
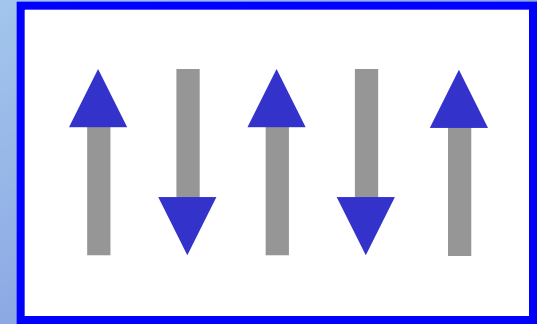
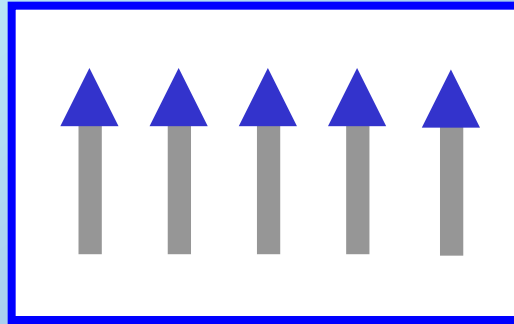
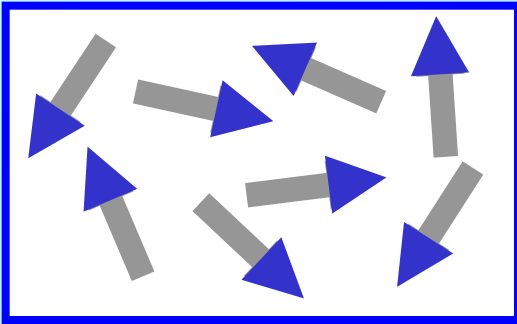

# Types of Magnetism

**Paramagnetism**

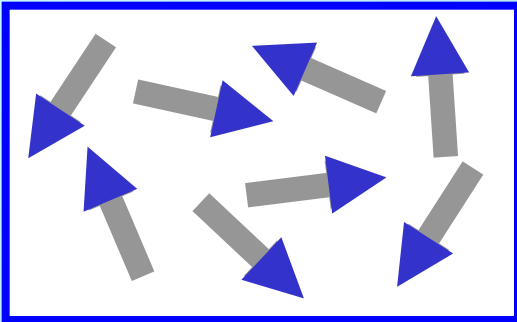

**Ferromagnetism**

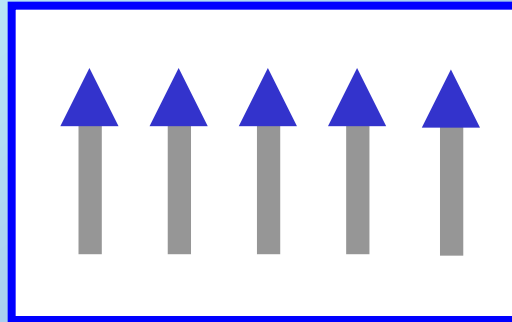

**Antiferromagnetism**

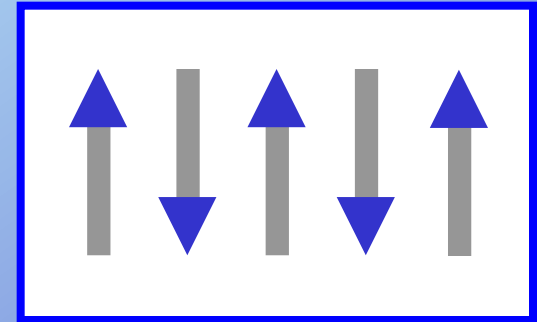

**Ferrimagnetism**

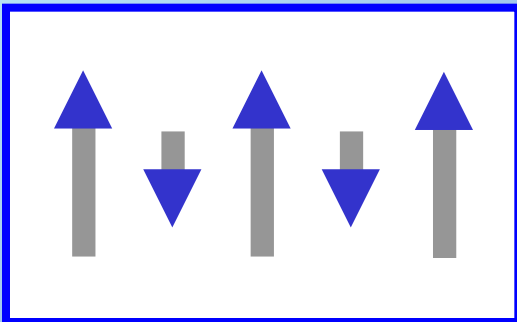

**Spin-Canted**

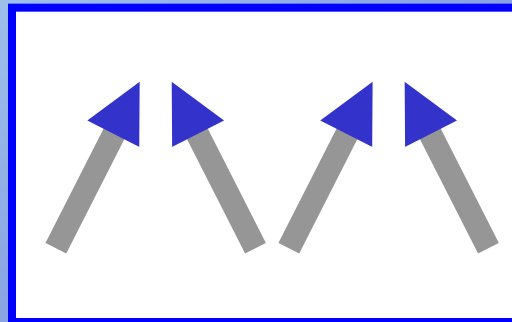

**Helimagnetism**

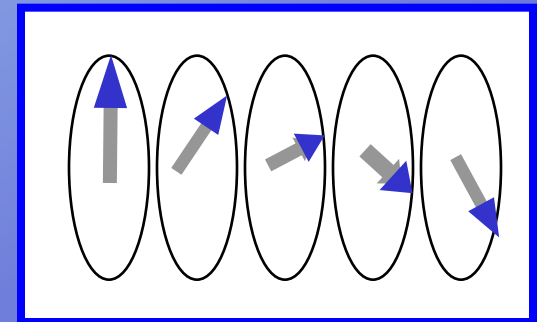

# Magnetic Domains ?

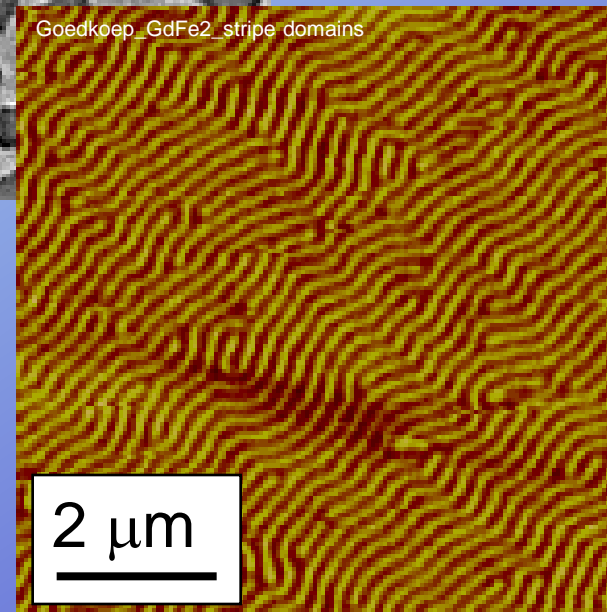
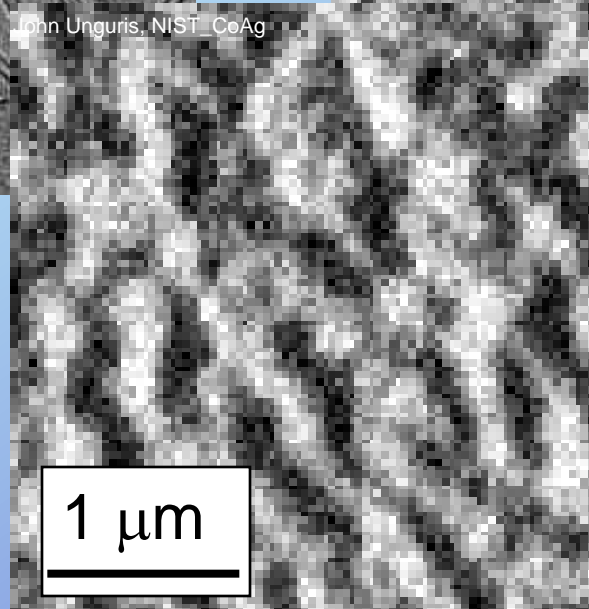
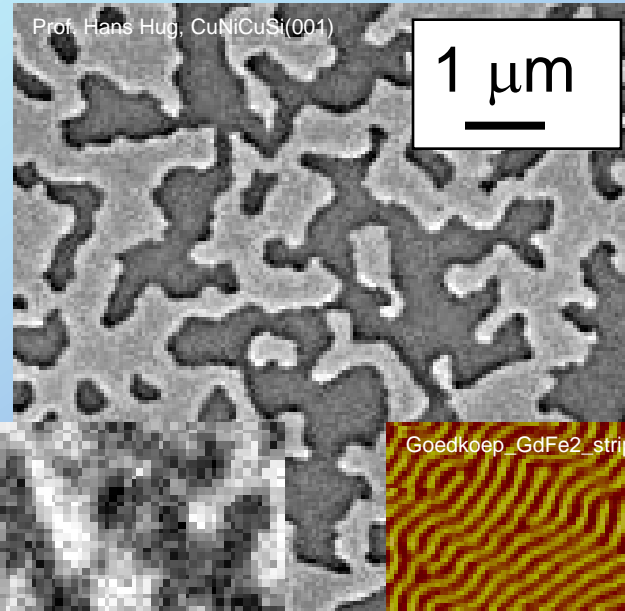
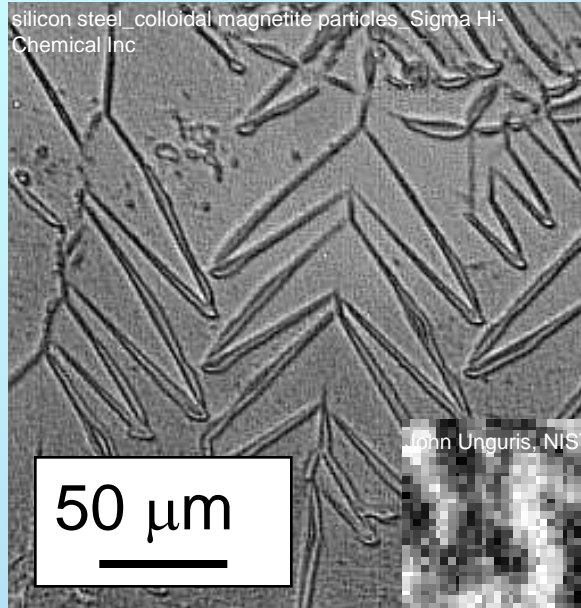

# Imaging Techniques

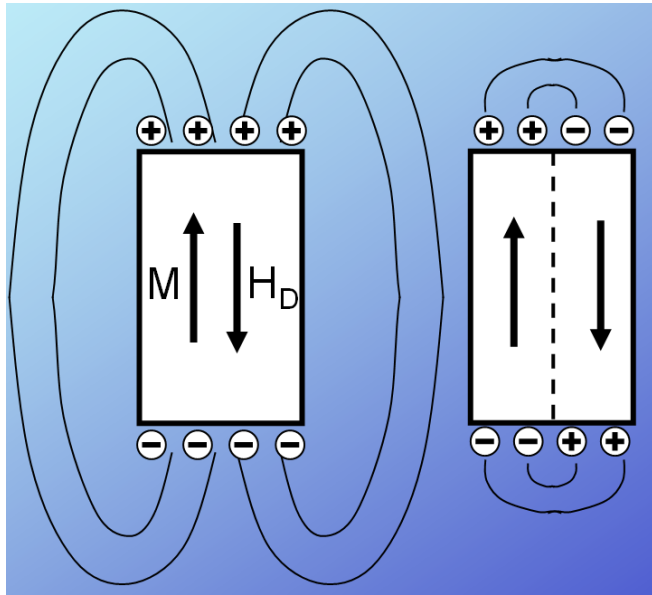

- Magnetic flux density (or induction):

$$\mathbf{B} = \mu_0 \mathbf{H} + \mathbf{J}$$

$\mathbf{H}$  = magnetic field (external + stray field)

$\mathbf{J}$  = magnetic polarization (magnetization  $\mu_0 \mathbf{M}$   
=  $\mathbf{q}/V$  magnetic moment / volume)

- Maxwell's equation  $\text{div} \mathbf{B} = 0$ , therefore:  
 $\text{div} \mathbf{H} = -\text{div} \mathbf{M} \rightarrow$  any divergence of  $\mathbf{M}$  creates a stray field  $\mathbf{H}$  (zero external field)

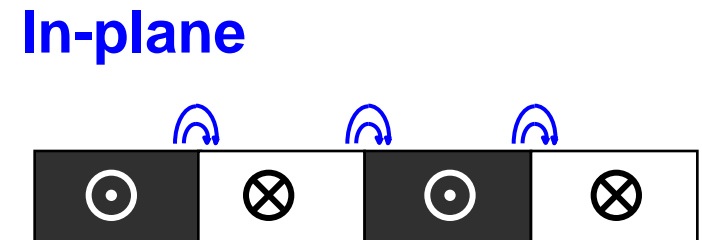
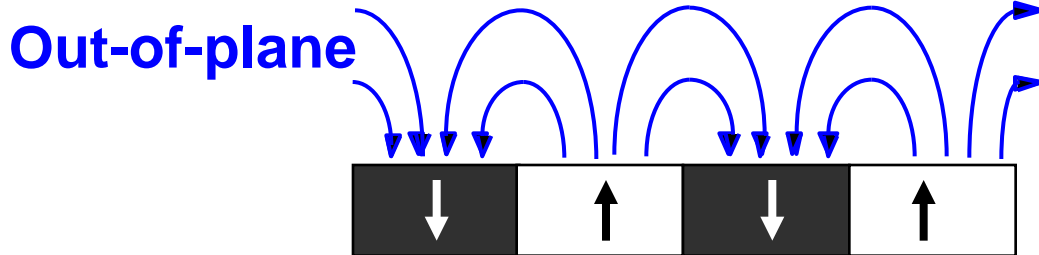

*Imaging techniques provide information on (i) stray field, (ii) magnetization (magnitude and direction), (iii) magnetic induction (includes stray field and magnetization) at material surface or through a thin film*

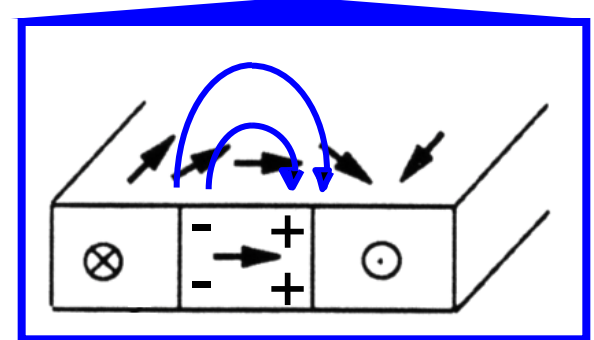

# Imaging Techniques

Bitter Technique

Scanning Probe Microscopy

Electron Microscopy

Kerr Microscopy

X-Ray Microscopy Techniques

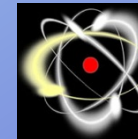
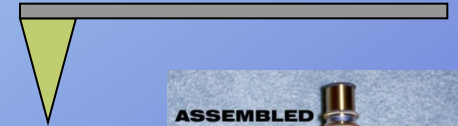
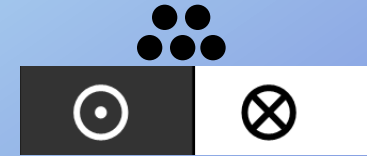

# Imaging Techniques

Bitter Technique

Scanning Probe Microscopy

Electron Microscopy

Kerr Microscopy

X-Ray Microscopy Techniques

